

Norfolk Projects Offshore Wind Farms Kittiwake Implementation and Monitoring Plan

Annex 4 Kittiwake Structure Detailed Design Report

Developer: Norfolk Boreas / Norfolk Vanguard Limited
Document Reference: PB5640.008.0056

Date: November 2022
Revision: Version 1
Author: Royal HaskoningDHV

Photo: Kentish Flats Offshore Wind Farm

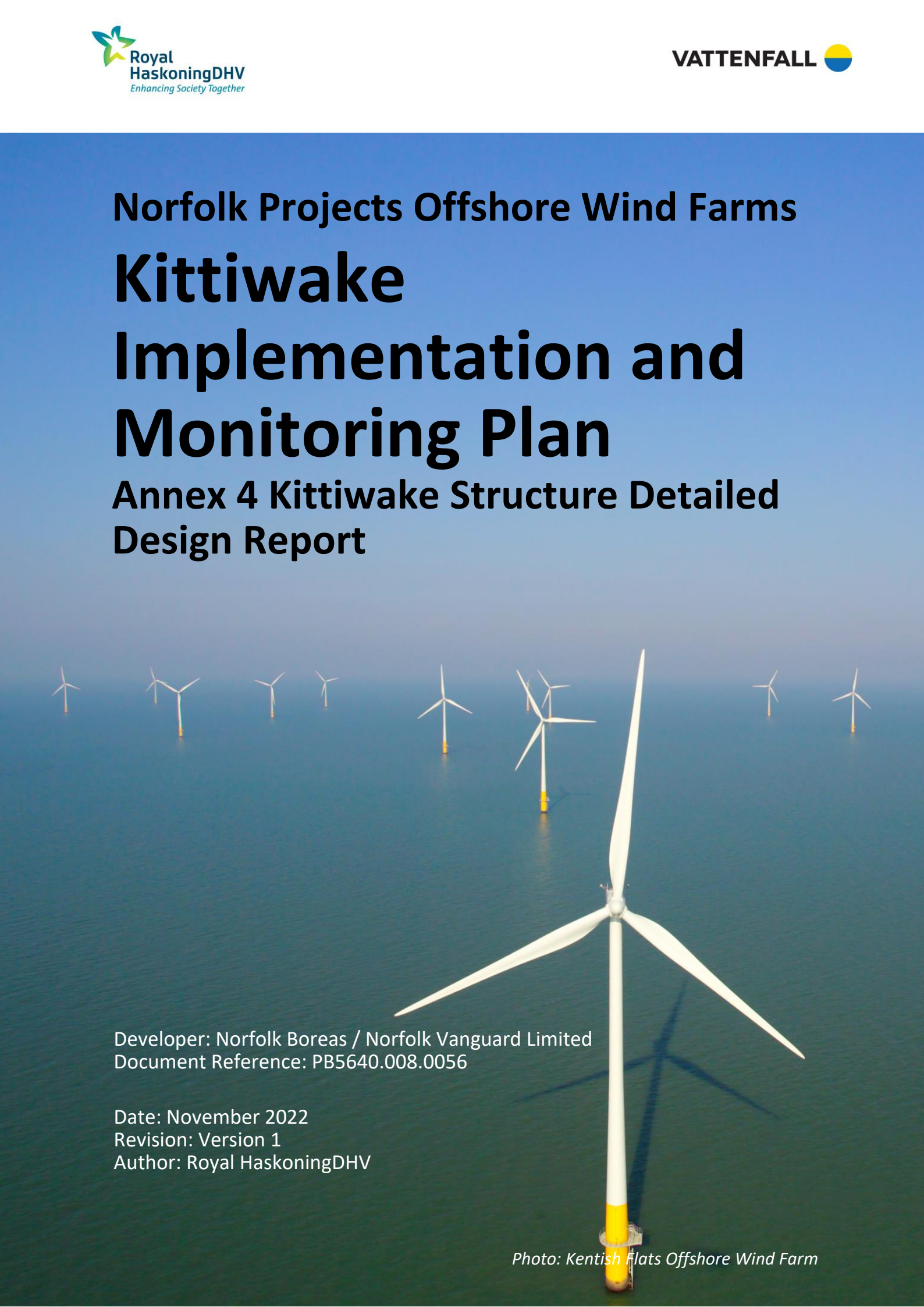

REPORT

Kittiwake Artificial Nesting Structures - Detailed Design Report

Client: Vattenfall

Reference: PC2765-RHD-KWT-ZZ-RP-C-0001

Status: Final/001

Date: 15 June 2022



HASKONINGDHV UK LTD.

74/2 Commercial Quay
Leith
Commercial Street
Edinburgh
EH6 6LX
Water & Maritime
VAT registration number: 792428892

██████████ T
info.edinburgh@uk.rhdhv.com E
royalhaskoningdhv.com W

Document title: Kittiwake Artificial Nesting Structures - Detailed Design Report

Subtitle:
Reference: PC2765-RHD-KWT-ZZ-RP-C-0001
Status: 001/Final
Date: 15 June 2022
Project name: Kittiwake Artificial Nesting Structures
Project number: PC2765
Author(s): Musa Yilmaz

Drafted by: Musa Yilmaz

Checked by: Mark Trinder and Dave Tarrant

Date: 14/06/2022

Approved by: Jake Laws

Date: 15/06/2022

Classification

Project related

Unless otherwise agreed with the Client, no part of this document may be reproduced or made public or used for any purpose other than that for which the document was produced. HaskoningDHV UK Ltd. accepts no responsibility or liability whatsoever for this document other than towards the Client.

Please note: this document contains personal data of employees of HaskoningDHV UK Ltd.. Before publication or any other way of disclosing, consent needs to be obtained or this document needs to be anonymised, unless anonymisation of this document is prohibited by legislation.

Table of Contents

1	Introduction	1
2	Project Location	1
3	Kittiwake ANS – Wall	4
4	Kittiwake ANS – Tower	8
5	Conclusion	13
6	References	13

Table of Tables

No table of figures entries found.

Table of Figures

Figure 2.1 - Lowestoft Harbour & North Pier	1
Figure 2.2 – Lowestoft Harbour, showing the North Pier in centre of the image	2
Figure 2.3 – Indicative site layout at Proposed location of Tower Structures on North Pier	2
Figure 2.4 – Indicative site layout at the Proposed location of Wall Structures on North Pier	3
Figure 3.1 - Wall Structure Precast Concrete Element cross-section,	4
Figure 3.2 - Plan View of PC Element & Mass Concrete Foundations	5
Figure 3.3 - Plan view of a Nesting Cabinet in between two PC Wall Elements	5
Figure 3.4 - Nesting Cabinets: Plan and Side Views	6
Figure 3.5 - Plan view of the Wall structure with 7 No of PC Wall Elements	6
Figure 3.6 - Enclosure Back Structure - Section View (Left) and 3D View of Internal Frame	7
Figure 4.1 - Plan View of Tower Structure	8
Figure 4.2 - Main Steel Frame Elements of the Tower Structure	9
Figure 4.3 - Tower Structure Side View with Mass Concrete Foundations and Internal Ladders	10
Figure 4.4 - Plan View of Nesting Cabinets	10
Figure 4.5 - Nesting Cabinets Side View (Left) & Sectional View	11

1 Introduction

Royal HaskoningDHV (RHDHV) has been appointed by Vattenfall to develop wall and tower concept designs for Kittiwake Artificial Nesting Structures. Further to the selection of Lowestoft Harbour as one of the possible project locations, Vattenfall has nominated RHDHV to further develop these concepts for this location and to produce detailed design drawings, specifications, and bills of quantities. In addition, this report has been produced to provide clarification on the detailed design development.

2 Project Location

Lowestoft is a coastal town and the most easterly UK settlement, it is 110 miles (177 km) north-east of London, 38 miles (61 km) north-east of Ipswich and 22 miles (35 km) south-east of Norwich, and the main town in its district. Its development grew with the fishing industry and as a seaside resort with wide sandy beaches. As fishing declined, oil and gas exploitation in the North Sea in the 1960s took over. While these too have declined, Lowestoft is becoming a regional centre of the renewable energy industry.

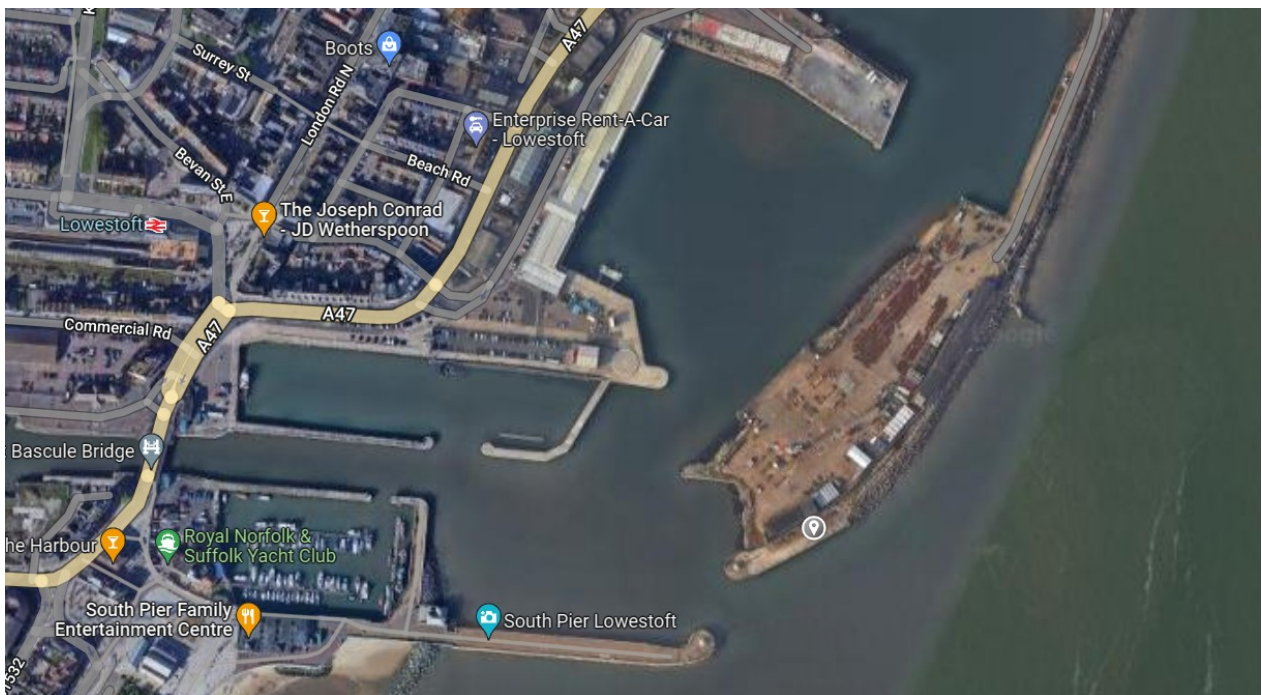

Figure 2.1 - Lowestoft Harbour & North Pier

Figure 2.1 shows the layout view of the Lowestoft Harbour. The North Pier is indicated with a grey location marker and Figure 2.2 provides a closer image of the North Pier. RHDHV has received a survey map of the North Pier with elevation and location information, however the civil/structural details of the underlying pier structure, such as details of the concrete slab and details of the quay wall were not available to RHDHV. It was therefore necessary to make assumptions regarding the foundation design of the structures, and these are highlighted in the following sections where relevant.

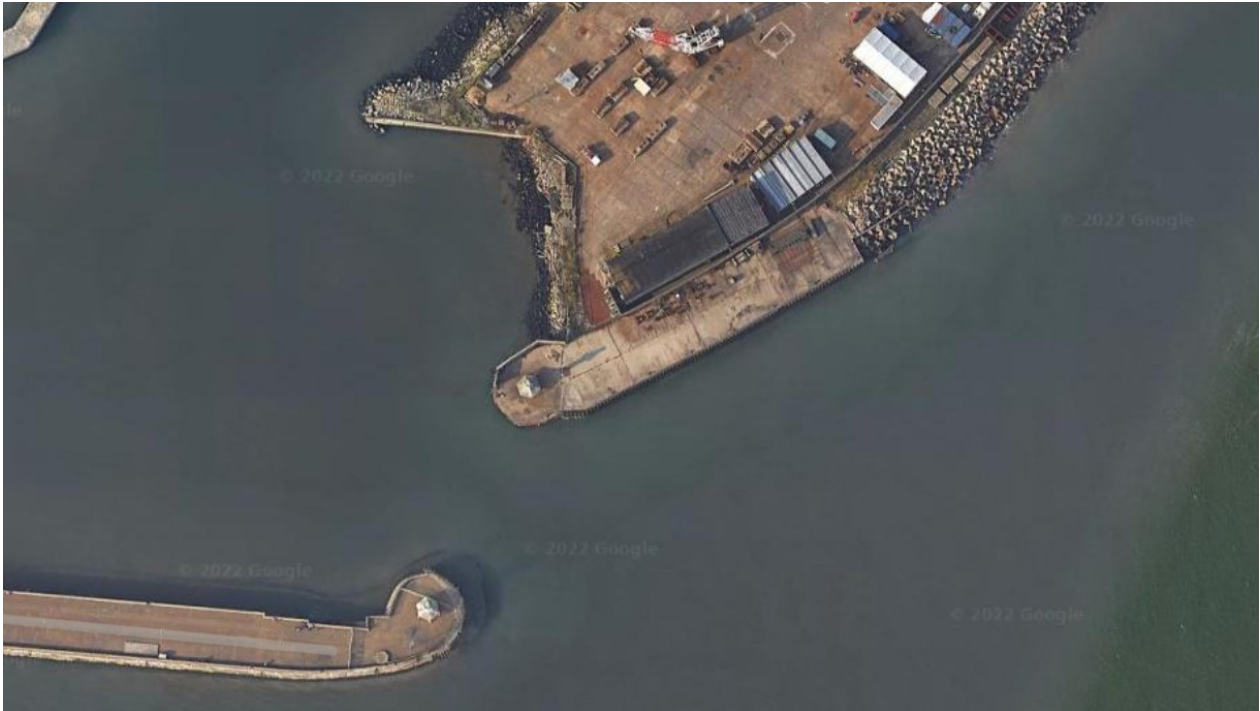

Figure 2.2 – Lowestoft Harbour, showing the North Pier in centre of the image

The below two figures (Figure 2.3 and Figure 2.4) present an indicative site layout of the proposed artificial nesting structures, both wall and tower structures, on the North Pier. For both design options, tower or wall, there will be three identical structures, all enclosed by a common predator proof fence boundary with two access gates.

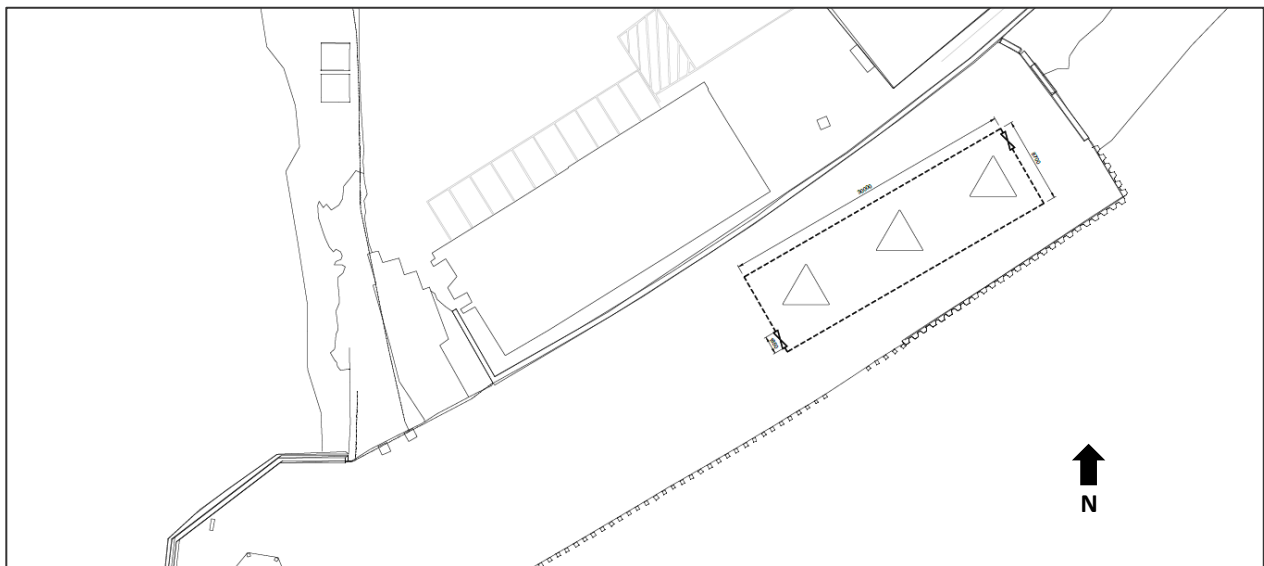

Figure 2.3 – Indicative site layout at Proposed location of Tower Structures on North Pier

The enclosure for the three tower structures would be 30.0 metres long 8.7 metres wide. The fence will be up to 2m high and have an overhang extending outwards to prevent foxes and other land-based predators from accessing the structures. The height and overhang will also minimise the potential for access to the compound by trespassers. The fence support posts will be located every 2.5 meters and they will be embedded into the ground with concrete foundations.

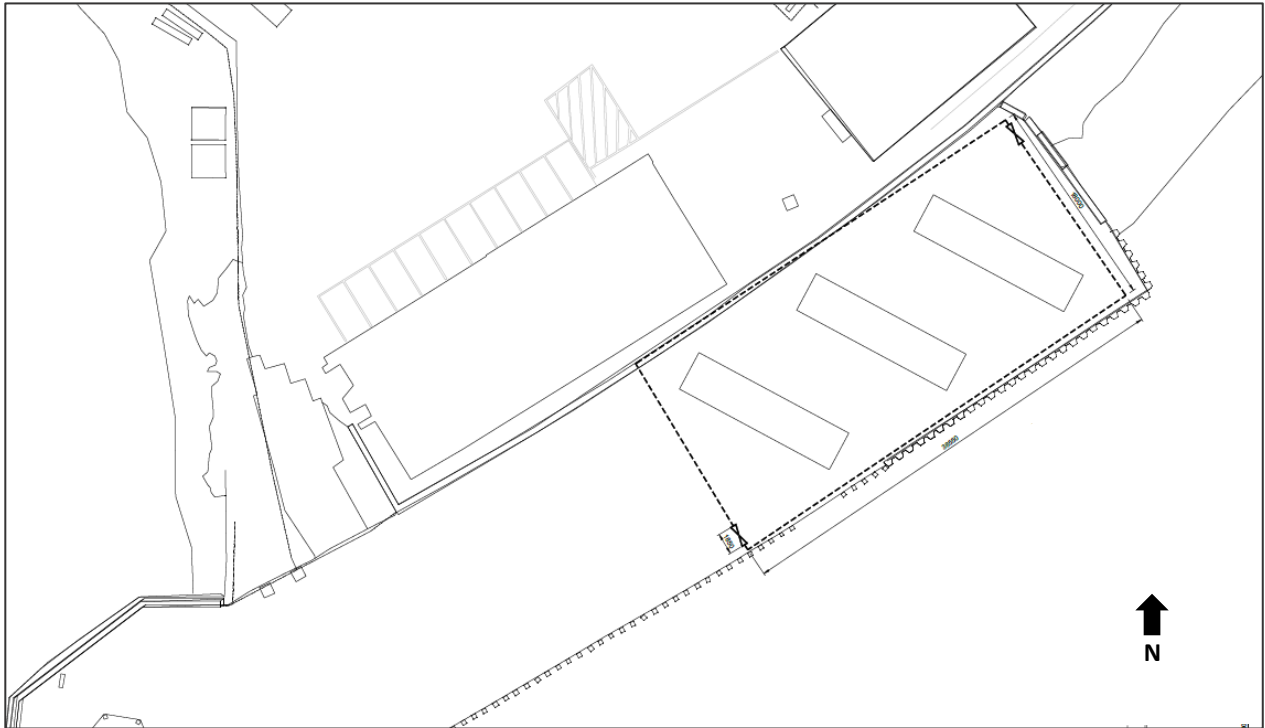

Figure 2.4 – Indicative site layout at the Proposed location of Wall Structures on North Pier

The enclosure for the three wall structures will be 38.55 metre long and 18.0 metres wide. The fence will be 2m high and have an overhanging extending outwards to prevent foxes from accessing the structures. The height and overhang will also minimise the potential for access to the compound by trespassers. The fence support posts will be located every 2.5 meters and they will be embedded into the ground with concrete foundations.

3 Kittiwake ANS – Wall

The Kittiwake Wall Structure will be constructed by using precast reinforced concrete elements as shown in Figure 3.1. The Precast Concrete (PC) elements will be constructed offsite and have a base width of 3.5m, length of 1.2m and a height of 4.15m and they can be individually transported to the project location. Prior to the installation of the PC wall elements, foundation works will be carried out for the wall structure.

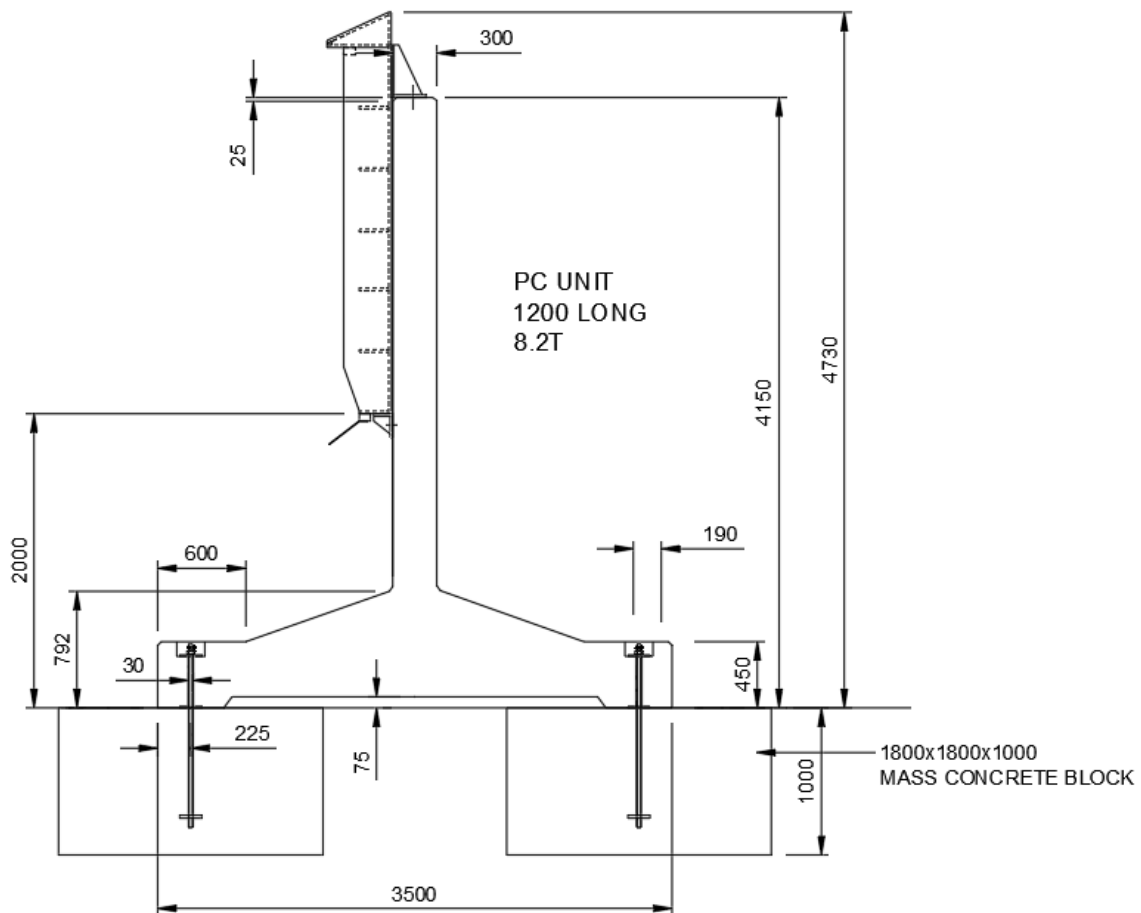

Figure 3.1 - Wall Structure Precast Concrete Element cross-section, (Showing width of base (3.5m), height 4.73 (inc. 4.15 PC), six shelf structures for kittiwake to nest on and overhanging top to protect from weather and aerial predators.)

Mass concrete blocks of 1.8m in length, 1.8m in width and 1.0m in depth will be buried and anchored on each side of the PC elements. Please refer to Figure 3.2 for plan view of a single PC element and its mass concrete foundations. Please note that the foundations will be anchored to the PC element at four locations, two on each side.

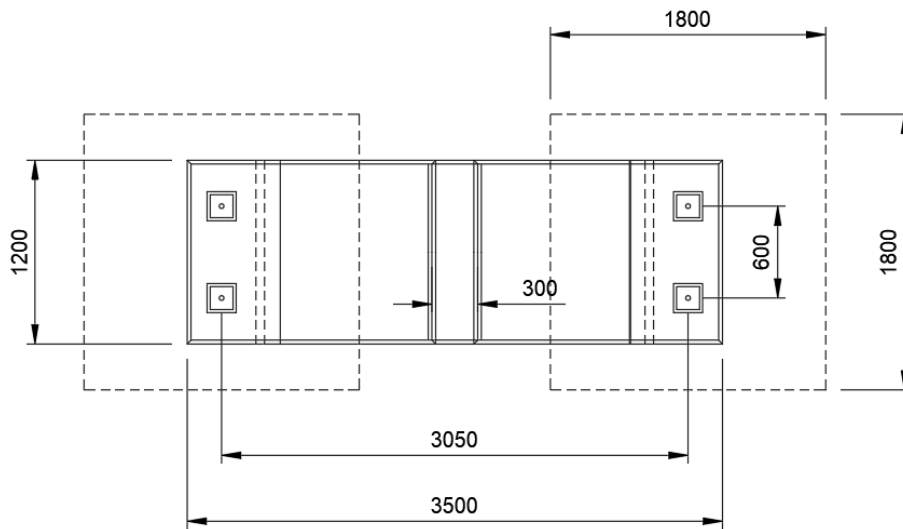

Figure 3.2 - Plan View of PC Element & Mass Concrete Foundations

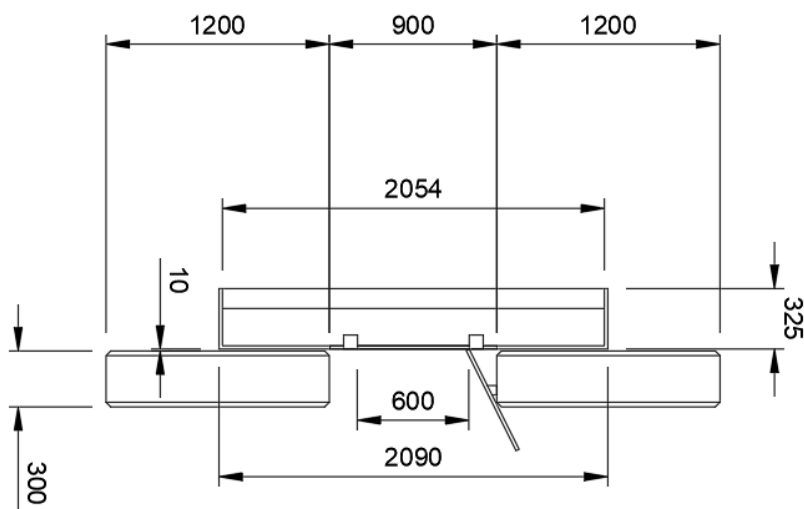

Figure 3.3 - Plan view of a Nesting Cabinet in between two PC Wall Elements

The nesting cabinets for Kittiwakes will be installed in between two adjacent PC wall elements as shown in Figure 3.3. The design of the nesting cabinets has been based on kittiwake nesting success studies commissioned by the Norfolk Projects (MacArthur Green 2021). The two adjacent PC wall elements will have a gap of 0.9m in between each other to allow inspection openings on the back of the nesting cabinets, a design feature requested by the Norfolk Projects Kittiwake Steering Group.

The nesting cabinets will have a length of 2.09m and a height of 2.7m. Each cabinet will have 6 shelves of 2.054m in length. The lowest shelves have a width of 0.1m and the top shelf will have a width of 0.2m as seen in Figure 3.4. The shelf widths are staggered in this manner, increasing in width up the shelf unit, to minimise fouling of lower nests by birds on upper shelves. Each shelf will have a height of 0.4m and an opening on the back will offer access to the nests to allow chicks to be weighed and ringed. The overhanging top will prevent access from aerial predators and protect against weather.

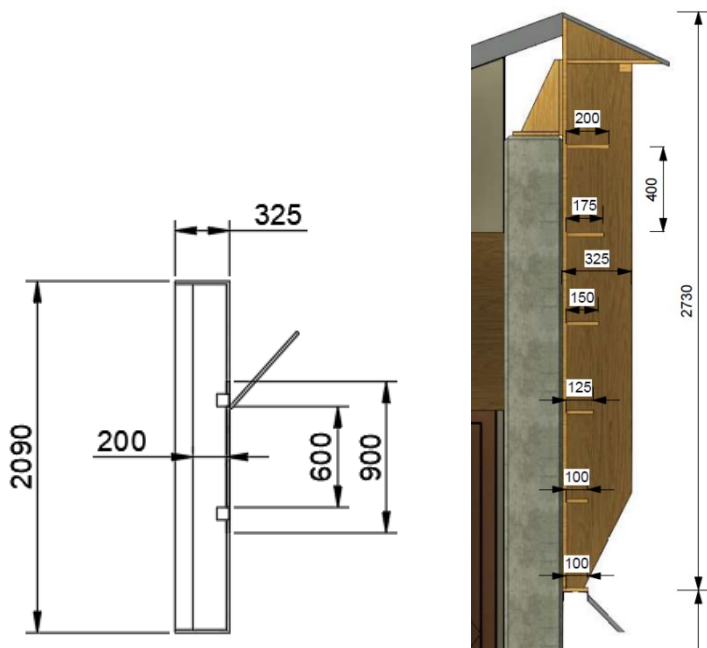

Figure 3.4 - Nesting Cabinets: Plan and Side Views

A width of 0.5m per nest has been allowed in the design of the nesting cabinets. Each nesting cabinet will have a total shelf length of $6 \times 2 = 12$ metres, which should accommodate 24 nests. To provide the target space for kittiwake nests, a total of 6 cabinets will be located in between 7 no of PC wall elements as shown in Figure 3.5 below. This will create a wall 13.8m in length with space for an estimated 144 nests (6 cabinets x 24 nests). The three wall structures will therefore offer a total capacity of 432 nests.

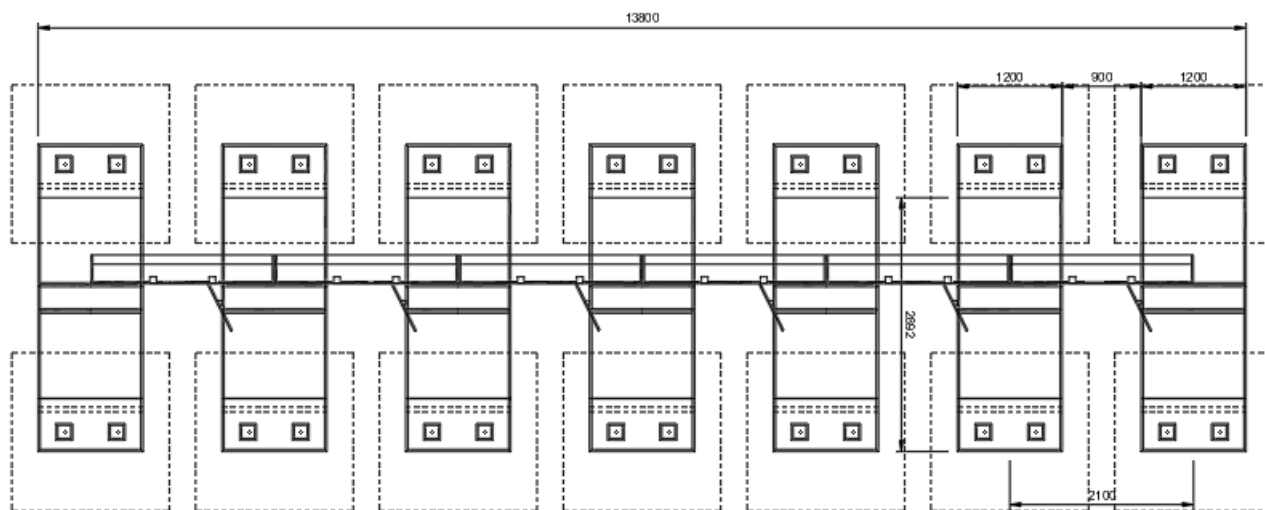

Figure 3.5 - Plan view of the Wall structure with 7 No of PC Wall Elements

In this project, modern methods of construction will be utilized, and both the PC wall units and the nesting cabinets will be constructed off-site. Please note that this will have significant benefits in reducing waste and carbon footprint of the contractor.

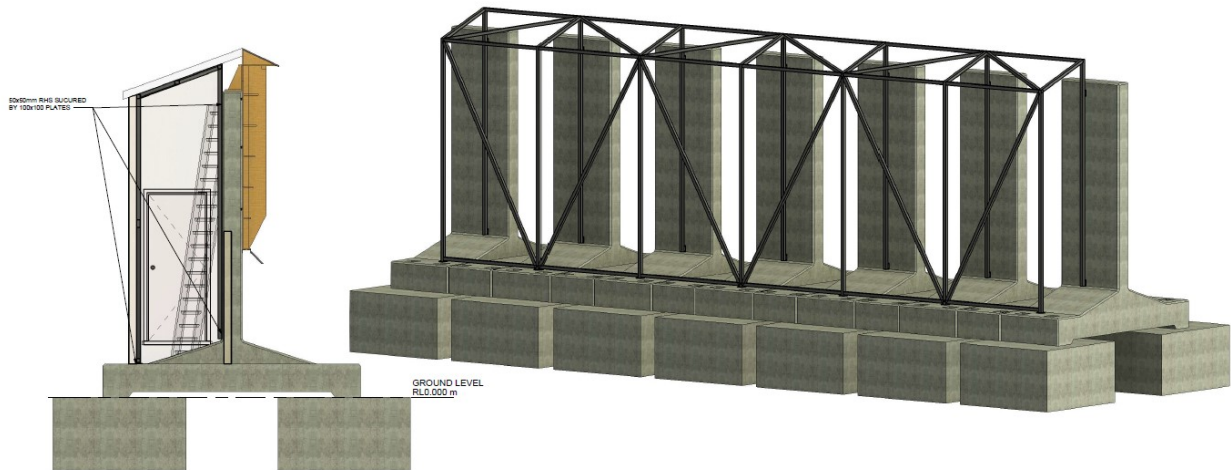

Figure 3.6 - Enclosure Back Structure - Section View (Left) and 3D View of Internal Frame

Further to installation of the PC wall elements, an infill mass concrete element of 3.5m in length, 0.45m in depth and 0.9m in width will be also placed in between each PC wall element with a debonding board (such as resin bonded corkboard of 15mm thickness) against the side face of the PC wall elements.

Finally, a complete back enclosure structure will be constructed to cover the entire back façade of the wall structure. Please refer to Figure 3.6 for the supporting frame details of the back enclosure structure with two access doors on each end and a movable ladder to be used to access all nesting shelves through the openings on the back of the cabinets.

The wall structures will be placed to have the nesting panels oriented towards north, to protect the nests from over-heating. The back side of the nesting shelves will be enclosed and this will eliminate any noise or light disturbance to the nests during any inspection or monitoring.

In reference to the lack of site data, RHDHV has assumed that the current project location shown in Figure 2.4 have the suitable ground conditions to undertake the dead weight of the wall structure at its entirety with mass concrete foundations, pre-cast concrete elements, nesting cabinets and back enclosure. Please also note that the wind loads on the wall structures are calculated in accordance with Eurocode EN 1991-1-4:2005+A1:2010 Section 7.4.1.

4 Kittiwake ANS – Tower

The Kittiwake Tower structure will be constructed of high yield steel with a paint system complying with C5M/Im2 marine standard. This will enable the structures to resist the harsh weather conditions of the North Sea.

The tower structures will be triangular in plan with vertical steel columns located in each corner, spaced 3.2m from centre to centre, as seen in Figure 4.1.

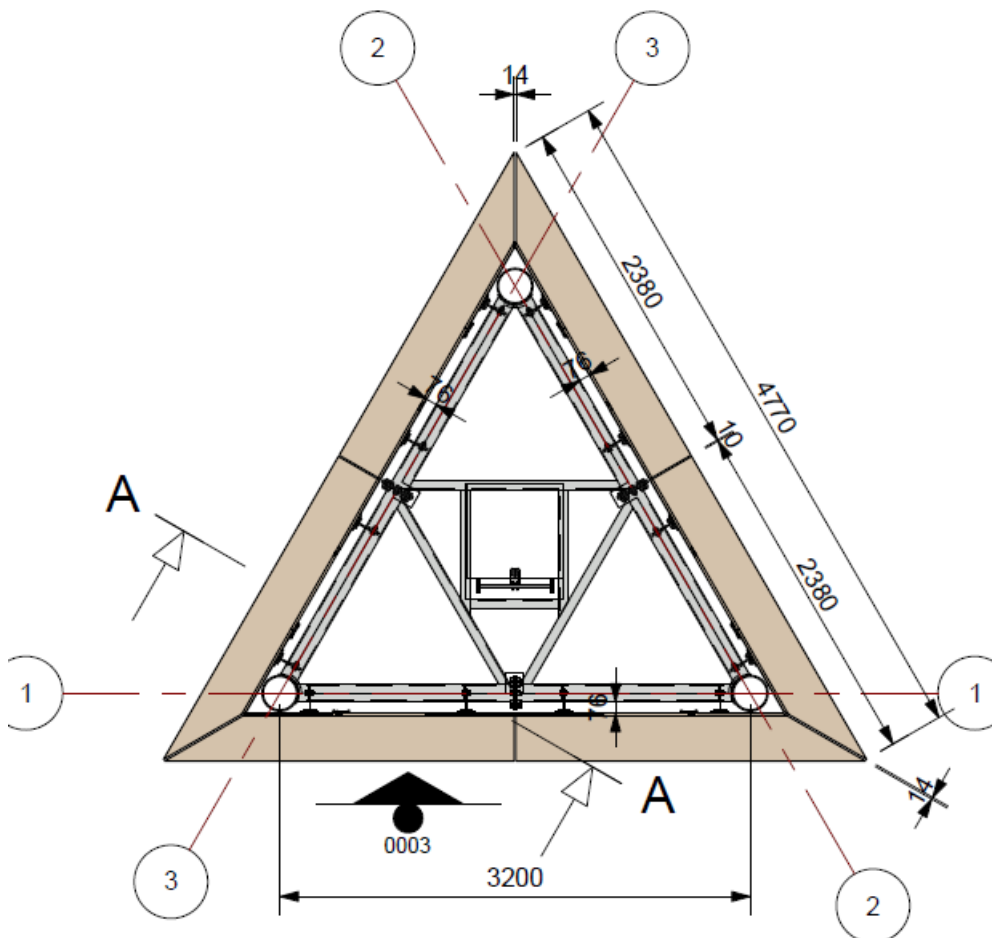

Figure 4.1 - Plan View of Tower Structure

The tower structure will have three internal levels, the first and second levels will be accessible via an internal vertical staircase with pull-up safety hatch panels. The third level is the top of the tower structure and will be enclosed with no access.

Please refer to the below figure for the main structural steel frame of the tower structure, where diagonal bracings are oriented to have minimum restrictions on the operation of the access panel openings on the back of the nesting panels.

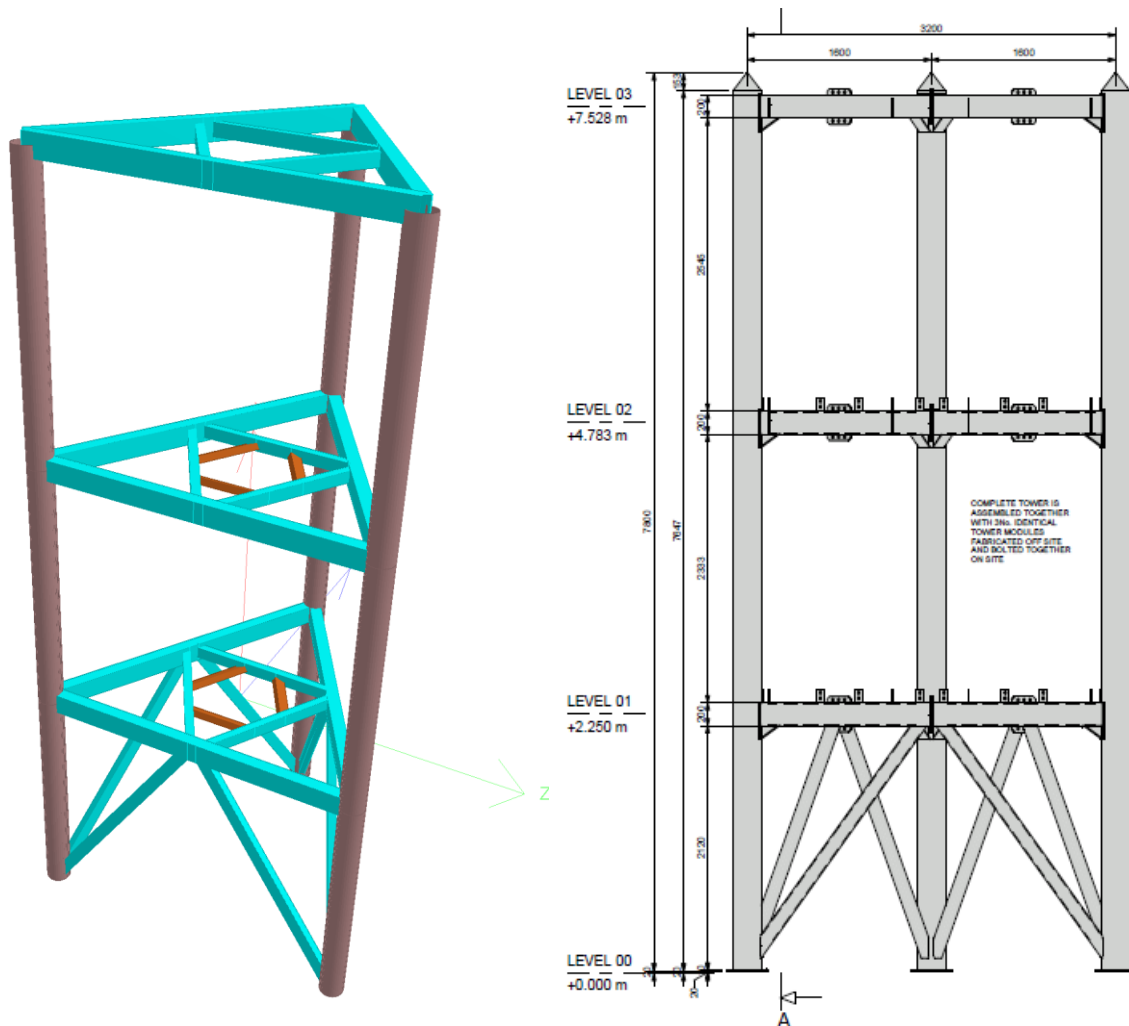

Figure 4.2 - Main Steel Frame Elements of the Tower Structure

The steel structural frame elements of the Tower structure (Figure 4.2), will be prefabricated at an off-site location as per the detailed design drawings and transported to site for assembly. Prior to the start of the installation, foundation works will be also carried out for the tower structure. Mass concrete blocks of 2.0m in length, 2.0m in width and 1.2m in depth will be buried and anchored on each corner of the tower structures. Please refer to Figure 4.3 for the side view of the tower structure and its mass concrete foundations.

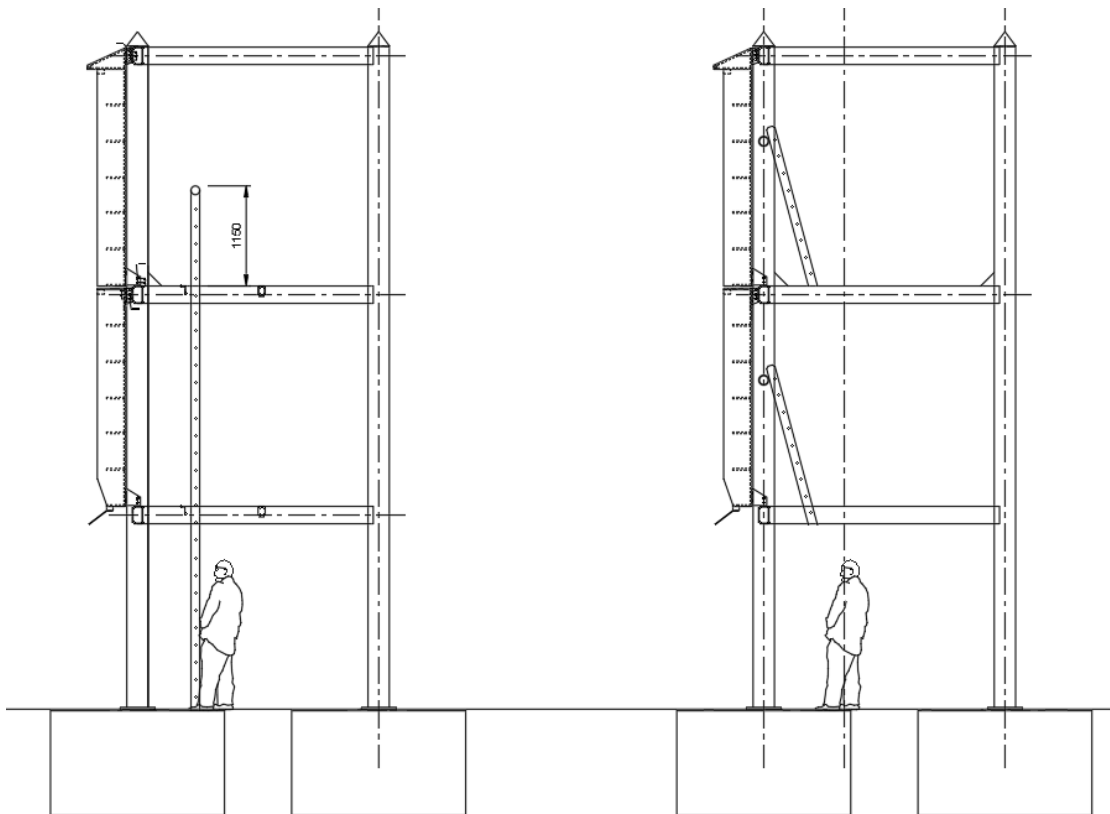

Figure 4.3 - Tower Structure Side View with Mass Concrete Foundations and Internal Ladders

As seen in Figure 4.3 and Figure 4.5, the nesting cabinets will be installed on the external façade of the tower structure. A total of 36 cabinets (4 on each façade of the tower) will be prefabricated and transported to the project site prior to installation. Please note that utilizing such off-site modular construction methods will have significant benefits in reducing waste and carbon footprint of the contractor.

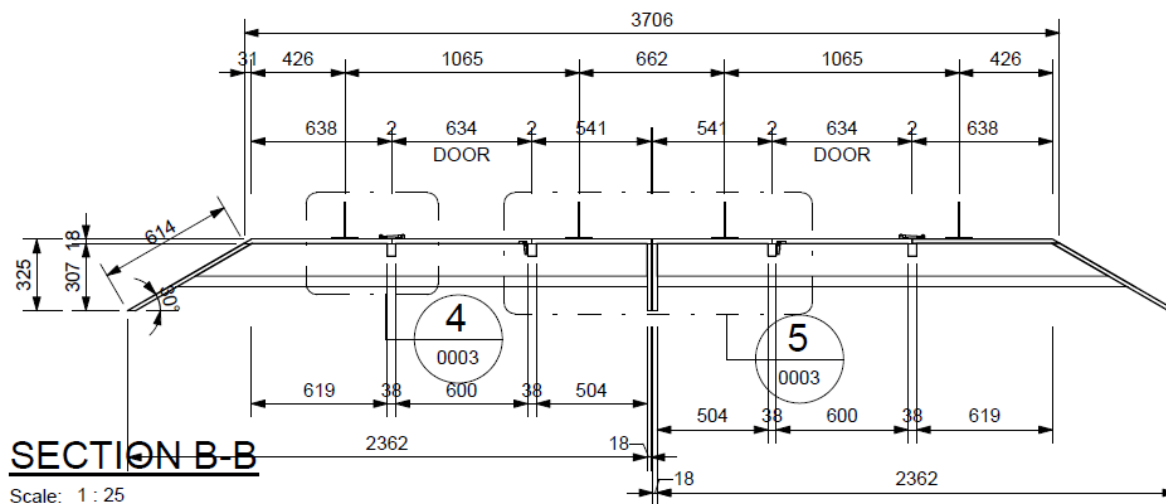

Figure 4.4 - Plan View of Nesting Cabinets

The nesting cabinets will have a length of 2.3m and a height of 2.5m. Each cabinet will have 6 shelves of 1.85m in length. The lowest shelves have a width of 0.1m and the top shelf will have a width of 0.2m as seen in Figure 4.4 and Figure 4.5. Each shelf will have a height of 0.4m and an opening on the back of the cabinets will allow inspection of the Kittiwakes.

During the design of the nesting cabinets, RHDHV has referred to kittiwake nesting success studies undertaken by MacArthur Green (2021). A width of 0.5m per nest has been allowed in the design works. Each nesting cabinet will have a total effective shelf length of $6 \times 1.5 = 9$ metres, which should accommodate 18 nests. The tower structure will have 3 facades and each façade will have 4 nesting cabinets. This will create a tower structure with a total nest capacity of 216 nests (3 facades x 4 cabinets x 18 nests). However, as one façade will face predominantly southwards which is expected to result in lower occupancy and poorer nesting success, total nest capacity had been calculated on the basis of only two facades per tower structure, hence total nest capacity per tower is estimated at 144 (2 facades x 4 cabinets x 18 nests). The three tower structures will therefore offer a total capacity of 432 nests.

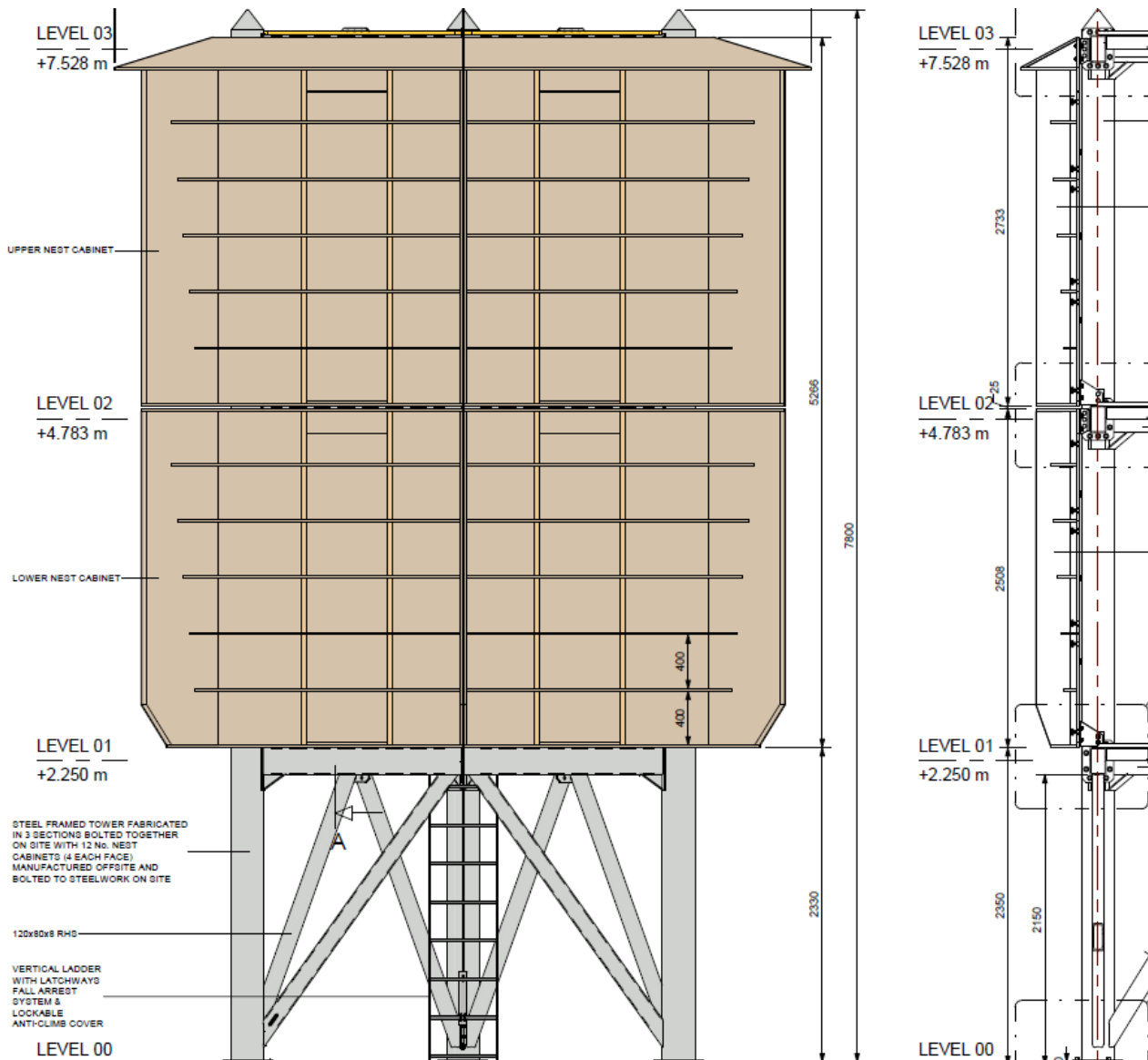

Figure 4.5 - Nesting Cabinets Side View (Left) & Sectional View

Due to its triangular shape, the tower structure will inherently create an internal enclosure that will enable the inspection of the Kittiwake nests with minimum disturbance to Kittiwake nests. A vertical access ladder will enable access to the first and second levels of the tower structure. At each level, a movable access ladder will allow inspection of the Kittiwake nests via the access panel openings that is located on the back of the nesting cabinets.

As mentioned previously, a total of 3 tower structures will be constructed on top of the Lowestoft Harbour North Pier, please refer to Figure 2.3. The triangular shaped tower structures will be placed to have two of the facades oriented towards north. Since the tower structure will be completely enclosed, it will also eliminate any noise or light disturbance to the nests during any future inspection.

In reference to the lack of site data, RHDHV has assumed that the current project location shown in Figure 2.3 have the suitable ground conditions to undertake the dead weight of the tower structure at its entirety with mass concrete foundations, steel structural framing elements, nesting cabinets and internal levels. Please also note that the wind loads on the tower structures are calculated in accordance with Eurocode EN 1991-1-4:2005+A1:2010 Section 7.4.1.

5 Conclusion

Kittiwakes are seabirds which naturally breed in colonies on vertical rocky sea cliffs but will also make use of manmade structures for nesting where these provide suitable location (narrow ledges), building substantial nests from available resources such as mud, grass and marine vegetation (sometimes including feathers).

The tower and wall structures detailed in this report have been designed in accordance with studies of kittiwake colonies on manmade structures such as MacArthur Green study (2021) on Kittiwake breeding success on artificial nesting structures and other material studies referenced within that report. The structures therefore provide narrow ledges, protected from weather and predators, both mammalian (e.g. foxes) and aerial (e.g. large gull species). The total nesting space provided reflects observations that kittiwake typically space themselves approximately 50cm apart, which minimise antagonistic behaviour between neighbouring pairs. Studies also indicate that south facing pairs have lower reproductive success, hence the walls have been oriented with a predominant northerly aspect while the estimated space provided on the towers does not include one side (i.e. the assumed south facing one).

Both structural options are considered suitable for kittiwake to nest on and permits flexibility in determining which is better suited for any given location.

6 References

MacArthur Green, 2021, Kittiwakes nesting on artificial structures: features of nest sites and nesting success at Lowestoft, Tyne and Dunbar (Report can be provided on request)